

The Power of Illumination

www.bplust.com

Miniature Star Series 75W Electronic Transformers

The MS Series is the solution to your low voltage 120V power requirements. Many qualities that you are looking for are available in the MS Series transformers' miniature casing. With a maximum load of 75W, it is suitable for 12V or 24V lamps.

The MS Series features 2 dimming options: it can have variable lighting level if used with a regular incandescent dimmer or have 2 intensity levels (hi-low) with a singlepole/triple-throw (SPTT) switch. In operation, the transformers are quiet even under dimming conditions. Some models are equipped with short circuit and overload auto reset protection.

B+L Technologies MS Series transformers offers you multiple possibilities to meet your requirements and please your customers.



DIMENSIONS

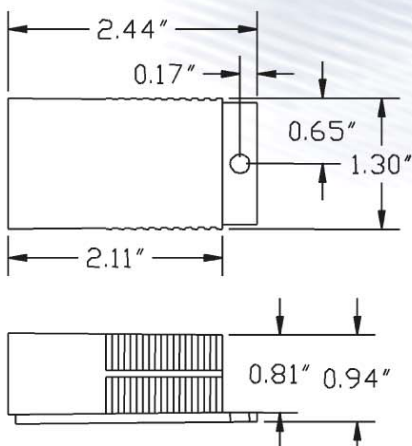

Figures shown with optional mounting bracket

GENERAL SPECIFICATIONS

- Miniature casing
- Maximum load of 75W
- Input 120V 50/60Hz
- Input current: 0.59 A
- For 12V or 24V halogen lamps
- Dimmable or Hi/Low intensity levels
- Short circuit auto reset protection
- Overload auto reset protection
- Power factor .98
- THD 13%
- Operating frequency > 20kHz
- Class A insulation system (Maximum transformer temperature of 90°C)
- Minimum load of 35W (20W for MS90118 & MS90218)
- Generally, the dimmer should have a minimum load of 40W for proper functioning



1-800-361-1400



ORDERING INFORMATION

120V-12V

MODEL NO.	OVERLOAD PROTECTION	SHORT CIRCUIT PROTECTION	AUTO RESET PROTECTION	DIMMABLE	HI-LOW INTENSITY LEVEL
MS90117	YES	YES	YES	YES	
MS90118*				YES	
MS90119					YES

120V-24V

MODEL NO.	OVERLOAD PROTECTION	SHORT CIRCUIT PROTECTION	AUTO RESET PROTECTION	DIMMABLE	HI-LOW INTENSITY LEVEL
MS90217	YES	YES	YES	YES	
MS90218*				YES	
MS90219					YES

* Note : Minimum load of 20W

LAMPS CHARACTERISTICS

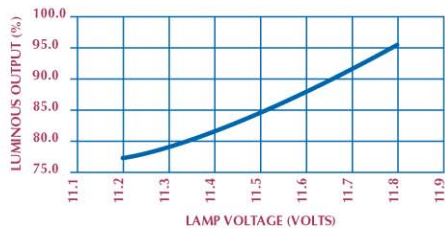
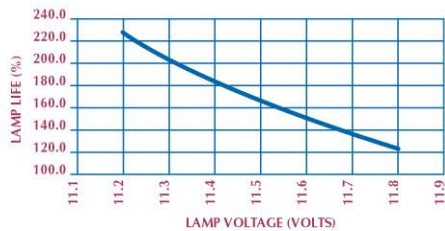
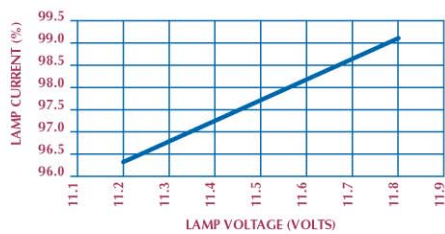

CABLING DIAGRAMS

**MS90117 & MS90118
MS90217 & MS90218**

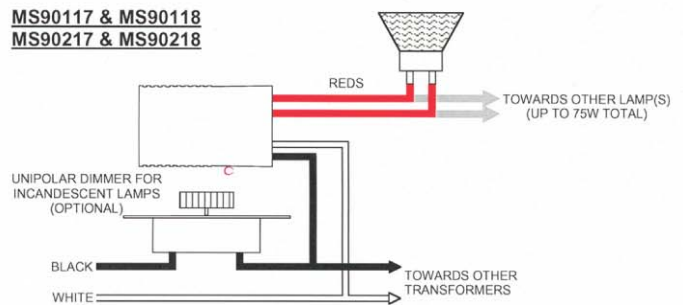

MS90119 & MS90219

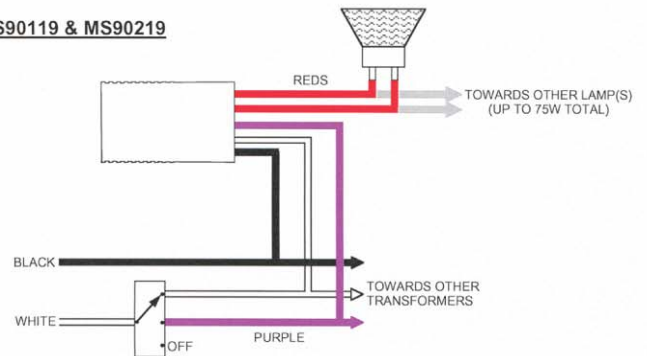

WIRE FROM SUPPLY	WIRE TO TRANSFORMER	LAMP(S) POWER
WHITE	WHITE	MAX POWER
WHITE	PURPLE	LOW POWER

WARRANTY

4 years from delivery date for:
MS Series 75W Transformers



3570 Charter Park Drive
San Jose, CA 95136
USA
Tel: (408) 269-7884
Toll free: (800) 361-1400
Fax: (408) 269-7638
www.bplust.com
info@bplust.com