

The Power of Illumination

www.bplusl.com

CV90033 240W DC Electronic Transformer



Dimensions

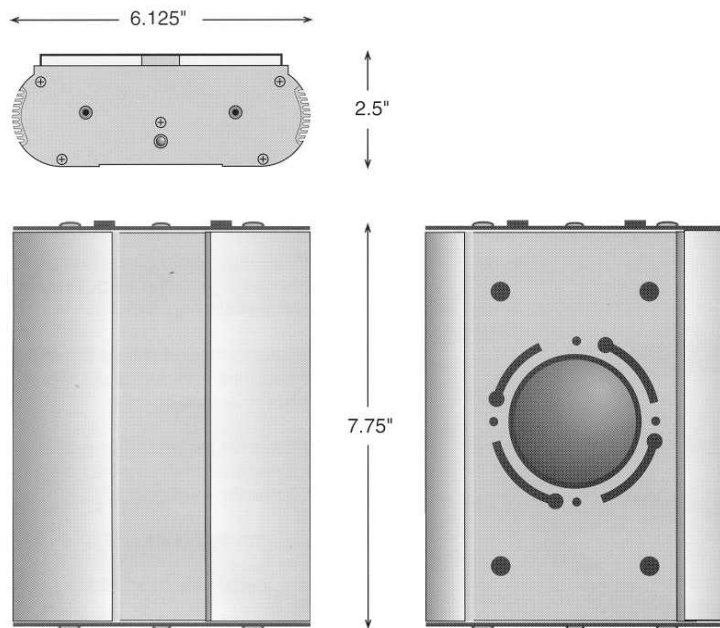

Designed to meet the distinct needs of bare conductor track systems, the CV90033 transformer is much more than a regular DC power supply.

Presented in an attractive aluminum casing, ready to be installed, the CV90033 will uniformly illuminate lamps of the cable lighting system without producing any sounds or vibrations.

The CV90033 surpasses CSA and UL security requirements. The transformer is equipped with two ultra rapid protection devices which prevent damage to the track system. The first device is a protection against accidental short circuits. A signal light mounted on the transformer casing, indicates if the short circuit protection is activated. The second protection, detects any variations of load to prevent the track system overload. The two protection devices stop and start up automatically the track system every 15 seconds until the short circuit or the overload are removed.

The CV90033 electronic converter is the best offer in the industry. It offers security and high performance to fulfill your customers' expectations.

1-800-361-1400



General Specifications

- ✓ High quality aluminum casing, available in black
- ✓ Can be ceiling or wall mounted
- ✓ Minimum load of 35W and maximum load of 240W
- ✓ Input voltage 120V 50/60Hz
- ✓ Input current: 2.2 A
- ✓ For 12V halogen lamps
- ✓ Compatible with standard incandescent dimmers
- ✓ Short-proof protection with ultra rapid response action (short circuit response time ≤ 8 ms); automatic reset
- ✓ Overload protection; detection of load variation and automatic reset
- ✓ Power factor: 0.95
- ✓ Total harmonic distortion (THD) $\leq 15\%$
- ✓ Operating frequency: > 20 kHz
- ✓ Class A isolation system, maximum transformer temperature of 90°C
- ✓ Generally, the dimmer should have a minimum load of 40W for proper functioning

Ordering Information

120V – 12VDC

MODEL NO.	OVERLOAD PROTECTION	SHORT CIRCUIT PROTECTION	AUTO RESET PROTECTION	DIMMABLE	RFI FILTER ON INLET AND OUTLET
CV90033	YES	YES	YES	YES	YES

Cabling Diagrams

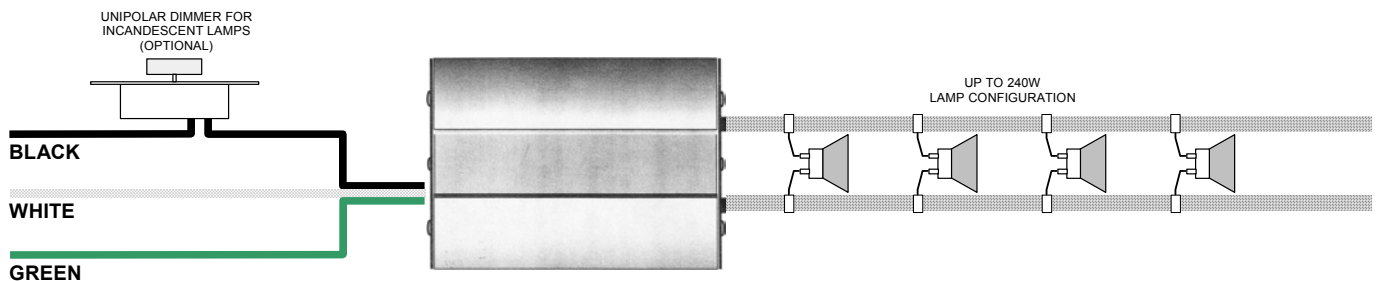

Warranty

2 years from delivery date for:
CV90033 Electronic Transformer



3570 Charter Park Drive
San Jose, CA 95136
USA
Tel.: (408) 269-7884
1-800-361-1400
Fax.: (408) 269-7638
www.bplust.com
info@bplust.com