

The Power of Illumination

www.bplusl.com

Land Star 75W Electronic Transformer



The Land Star transformer LS94117 is the solution to your low voltage 120V power requirements for outdoor applications. Outdoor and landscaping luminaries are exposed to extreme conditions where selection of components play an important role in fixture longevity and performance. B+L Technologies has designed the Land Star to meet these conditions. Potted with a silicone compound in a plastic casing, the transformer won't rust and will operate reliably in damp locations under harsh conditions.

Many qualities that you are looking for are available in the LS transformers' compact casing. It is designed to work with regular incandescent dimmers and the transformer operates quietly even under dimming conditions. The LS is equipped with the state of the art short circuit and overload auto reset protections.

B+L Technologies' Land Star transformer offers multiple possibilities to meet your requirements and to please your customers. Contact our customer service representatives to find out more about this and other lighting products.

General Specifications

- ✓ Compact plastic casing that won't corrode
- ✓ Very resistant to damp locations and harsh conditions
- ✓ Maximum load of 75W
- ✓ Input 120V 50/60Hz
- ✓ Input current: 0.59 A
- ✓ For 12V halogen lamps
- ✓ Dimmable
- ✓ Short circuit auto reset protection
- ✓ Overload auto reset protection
- ✓ THD: 13% Max.
- ✓ Power factor: 0.98 Min.
- ✓ Operating frequency > 20kHz
- ✓ Class A insulation system
- ✓ Maximum case operating temperature: 70°C
- ✓ Minimum operating temperature: -10°C
- ✓ Minimum lamp wattage of 35W
- ✓ Generally, the dimmer should have a minimum total lamp wattage of 40W for proper functioning
- ✓ Not suitable for LEDs

1-800-361-1400



Ordering Information

120VAC Input – 12VAC to Lamp

MODEL NO.	OVERLOAD PROTECTION	SHORT CIRCUIT PROTECTION	AUTOMATIC PROTECTION RESET	DIMMABLE	WITHSTANDS DAMP CONDITIONS
LS94117	YES	YES	YES	YES	YES

Dimensions

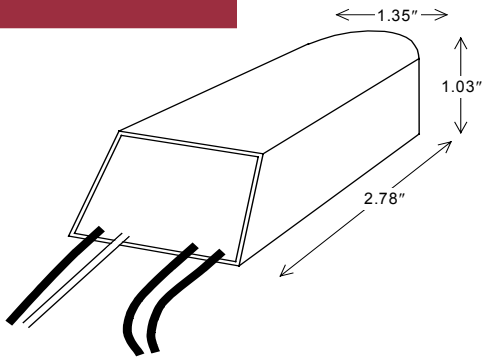

Cabling Diagrams

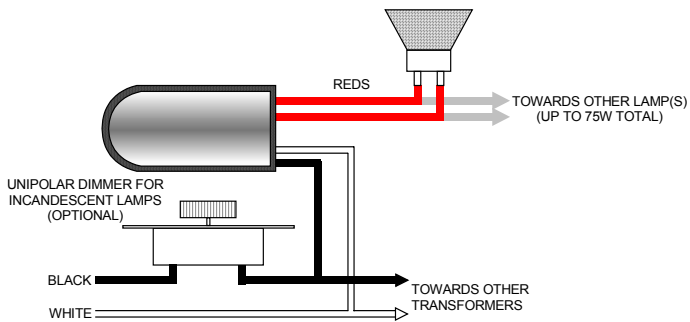

Note: Not approved for submersible or waterproof applications

Warranty

3 years from delivery date for:
LS 75W Transformer



3570 Charter Park Drive
 San Jose, CA 95136
 USA
 Tel.: (408) 269-7884
 1-800-361-1400
 Fax.: (408) 269-7638
www.bplusl.com
info@bplusl.com